



12636E00

- > Controlled electrostatic grounding of road tankers and rail cars during loading
- > Continuous monitoring of correct grounding
- > The object recognition prevents potential operator errors (with road tankers)
- > Water jet protected stainless steel enclosure IP65
- > Easy installation and operation
- > Two potential-free change-over contacts per channel for signalling







E4

WebCode 7485A

Zone	ATEX / GOST					
	0	1	2	20	21	22
Ex i interface		x	x		x	x
For use in			x		x	x

Technical Data		
Explosion protection Europe (ATEX) Ground monitoring device Gas and dust	FTZÚ 10 ATEX 0068 ⊕ II 3 (2) G Ex nAC ib [ib] IIC T4 ⊕ II 2 D Ex tD A21 T62°C IP65	
Clamp Gas and dust	FTZÚ 10 ATEX 0068 ⊕ II 2 GD Ex ib ibD IIB T40°C	
Certificates and approvals Certificates	ATEX, Russia (GOST R) applied for	
Power supply Rated voltage	230 +/- 10 % V AC	
Rated current	50 mA	
Power consumption	10 VA	
Output Signalling contact	two floating change-over contacts per channel	
Minimum load	10 V DC / 100 mA	
Maximum load DC	230 V DC / 0.25 A 40 V DC / 3 A	
Maximum load AC	230 V AC / 3 A	
Ambient temperature Operating temperature	- 20 ... + 40 °C	
Storage temperature	- 20 ... + 40 °C	
Degree of protection	IP65	
Material Enclosure	Stainless steel	
Grounding clamp	Galvanised steel, contact point: copper	
Assembly / Installation Cable glands	Cable diameter range 6 ... 12 mm	
Connection	Maximum diameter, single-wire	
	- rigid	2.5 mm ²
	- flexible	2.5 mm ²
	- flexible, cable end sleeves with plastic cover	1.5 mm ²
	- flexible, cable end sleeves without plastic cover	2.5 mm ²

Selection Table

Version	Description	Order number	Art. no.	PS	Weight
					kg
 12637E00 Ground monitoring device	Single-channel ground monitoring device, without cable	7485/111-31	202505	54	7.900
 12638E00 Clamp with cable	10 m ÖLFLEX with cable gland *); Ambient temperature: - 50 ... + 60 °C		202500	54	2.900
 12640E00 Clamp with spiral cable	10 m ÖLFLEX with cable gland *); Ambient temperature: - 30 ... + 60 °C		202502	54	4.000
 12715E00 Grounding clamp with automatic cable winder	Automatic winder with 15 m of insulated cable and robust ergonomic grounding clamp, stainless steel, and fast-action plug - II 1 GD T6. Self retracting reel with 15 m Hytrel isolated cable		105544	54	16.000
 12643E00 Configuration set	Configuration set consisting of infrared adapter with USB port and CD-ROM with configuration software		202511	54	0.500

*) Special cable length possible on request (max. 20 m). Price and date of delivery differ from the standard.

Dimensional Drawings (All Dimensions in mm / inches) - Subject to Alterations

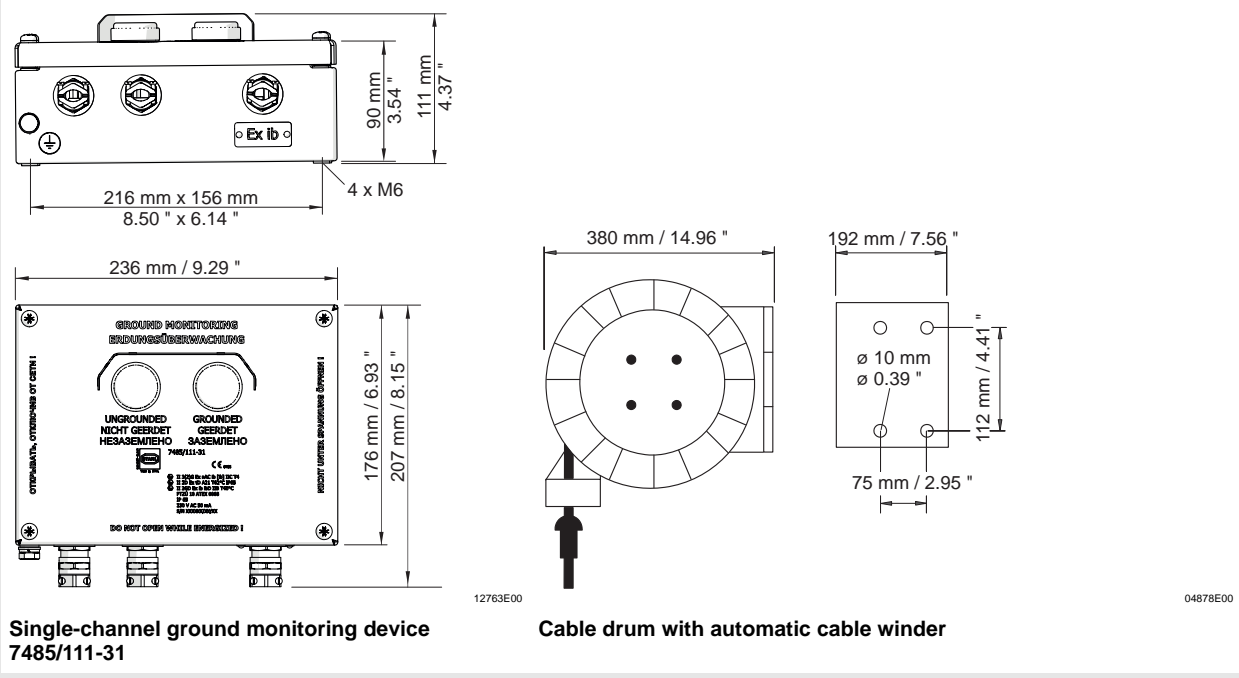

Single-channel ground monitoring device
7485/111-31

Cable drum with automatic cable winder

E4